



Heat Cycling Test Sets for Power Cables

Low Voltage, High Current Supply

- Standard models available up to 6000 Amps
- Indoor/Outdoor units available
- Automated Controls
- Temperature Regulating Controls



TESTING APPLICATIONS

- Perform type testing of a cable sample in accordance with applicable international standards (IEC, IEEE, IPCEA, AEIC, VDE, EDF)
- Perform inductive heating of cable samples and accessories
- Heated cable can be simultaneously stressed with DC or AC high voltage as well as impulse voltage with the inclusion of necessary options or by utilizing additional equipment

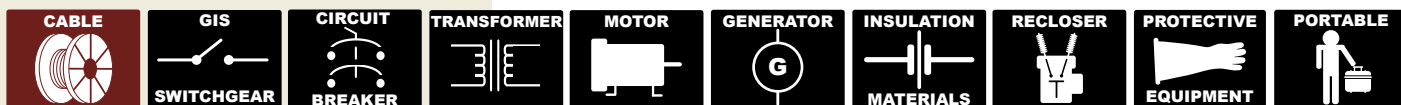

SIZING OF THE SYSTEM

The actual rating and design appropriate for a particular application depends on a number of factors.

- Conductor type and cross-section
- Insulation type and thickness
- Length of cable to be tested
- Ambient and test temperatures
- Time allowed to reach test temperature

SAFETY and DESIGN FEATURES

- Input circuit breaker
- Precision output metering
- Zero start interlock
- Thermal overload protection
- Overcurrent protection
- On/Off pushbuttons
- Heavy duty casters for mobility
- Complete Operation and Maintenance manual

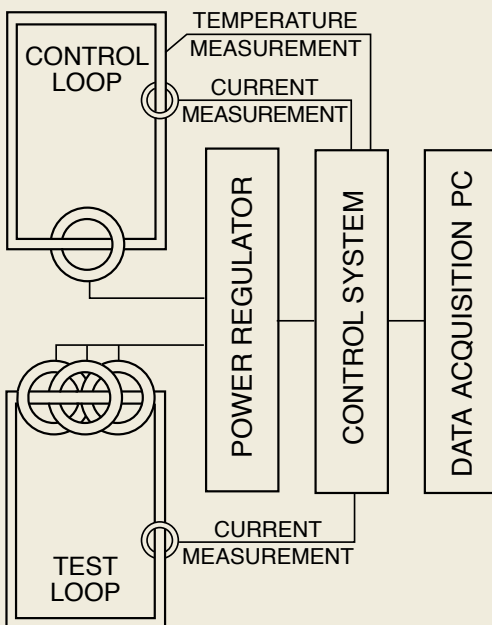

SCR VERSUS REGULATOR CONTROLLED SYSTEMS

SCR (Electronic Regulator) Controlled Systems

SCR (Silicon Control Rectifier) systems utilize a solid state regulator which offers faster rise time and instantaneous return to zero. The compact design allows the SCR to be maneuvered more easily. The SCR controlled system is proven to be a reliable and economical choice for many testing applications. SCR regulators are typically used on smaller systems as the SCR regulator is not compatible with capacitive compensation which is often used to reduce mains service requirements.

Regulator (Variable Autotransformer) Controlled Systems

Regulator systems utilize a column or toroidal variable auto transformer to control the output. This system produces a true sine wave over the full output range and operates at very low impedance. A master-slave setup can be implemented to expand testing capabilities for multiple units. Capacitive compensation is available to lower input power and regulator size and to reduce cost.

TEMPERATURE REGULATION

During a heat cycling test, voltage is applied in conjunction with high current to simulate operating conditions. A thermocouple is used for measurement of the conductor temperature. There are three testing options.

- Method 1, the thermocouple is bonded to the outer insulation of the cable. With this method the conductor temperature is previously calculated or established by testing without applied high voltage.
- Method 2 involves using an optional fiber optic temperature probe. With this probe, a hole is cut into the cable insulation and physical contact is made with the center conductor. The hole is filled with a compound to re-establish the dielectric strength of the insulation. The fiber optic probe may also be used during impulse testing.
- Method 3 utilizes two separate cable loops. A control loop, which is typically shorter, is used to connect the thermocouple to the conductor. No high voltage is applied to the control loop. A second test loop, which is typically longer, has high voltage applied. The control loop is used to exactly monitor conductor temperature while the LVTS control system maintains the same current in each loop, thus ensuring that the conductor temperature stays within prescribed limits.

COMPUTERIZED CONTROLS

Computerized controls, which consist of an industrial microprocessor, HMI, and a communications port implement all metering, timing and setpoint functionality. Computerized controls allow programming of complex custom sequences and in conjunction with a PC and software, allow for data acquisition and report generation.

HEATING TRANSFORMER CARTS

The heating transformers are constructed out of high quality grain oriented laminated core steel. The primary windings utilize copper conductor and are protected by barriers from the cable under test. The carts are designed to cool via natural air convection (AN).



		SCR and Regulator Controlled Systems					
MODEL		LVTS15-2000	LVTS30-3000	LVTS25-4000	LVTS20-5000	LVTS17-6000	
INPUT	KVA	30/36	90/108	100/120	100/120	100/120	
	Frequency	50 or 60 Hz (one must be specified)					
OUTPUT	Voltage 60 Hz	0-18 V	0-36 V	0-30 V	0-24 V	0-20 V	
	Voltage 50 Hz	0-15 V	0-30 V	0-25 V	0-20 V	0-17 V	
	Current	0-2000 A	0-3000 A	0-4000 A	0-5000 A	0-6000 A	
DUTY CYCLE		continuous					
DIGITAL METERING	Output Currentmeter	4 digit digital meter displays TRMS value of output current					
	Range	0-2000	0-3000	0-4000	0-5000	0-6000	
	Accuracy	+/-1% Full Scale					
	Output Voltmeter	4 digit digital meter displays TRMS value of output voltage					
	Range	0-18 V	0-36 V	0-30 V	0-24 V	0-20 V	
	Accuracy	+/-2% Full Scale					
CABLES	Interconnect	20' (6 m)					
		Power and ground cables are not included					
DIMENSIONS & WEIGHTS	Cart	Length	48" (1220 mm)	69" (1740 mm)	50" (1280 mm)	67" (1702 mm)	67" (1702 mm)
		Width	25" (650 mm)	32" (813 mm)	29" (737 mm)	36" (914 mm)	36" (914 mm)
		Height	42" (1060 mm)	52" (1320 mm)	37" (946 mm)	52" (1321 mm)	52" (1321 mm)
		Weight	1500 lbs (680 kgs)	1700 lbs (770 kgs)	2200 lbs (998 kgs)	2850 lbs (1291 kgs)	2850 lbs (1291 kgs)
	Controls	Length	20" (508 mm)				
		Width	17" (432 mm)				
		Height	12" (305 mm)				
		Weight	49 lbs (22 kgs)				
	Regulator (R Style Units Only)	Length	28" (711 mm)	42" 1067 mm)	34" (864 mm)	56" 1422 mm)	56" 1422 mm)
		Width	32" (813 mm)	32" (813 mm)	32" (813 mm)	32" (813 mm)	32" (813 mm)
		Height	52" (1321 mm)	66" 1676 mm)	56" 1422 mm)	58" 1473 mm)	58" 1473 mm)
		Weight	602 lbs (273 kgs)	1280 lbs (580 kgs)	1435 lbs (650 kgs)	1708 lbs (775 kgs)	1708 lbs (775 kgs)

NOTE: Other models are available upon request.

TESTING with LONG LOOPS

When testing cable accessories (splices, terminations, joints), very long testing loops may be required. The loops can be in excess of 200 m in length.

To accomplish energizing these longer loops, multiple carts are connected in series. For example, 5 x 20-5000 are used to make a 100 V, 5000 A loop.

ENVIRONMENTAL CONDITIONS

- 10-40°C, indoor/outdoor in fair weather
- Humidity <95% non-condensing
- Altitude <3300 ft (1000 meters)



OPTIONS

Transformer Cart Upgrade for Outdoor Operation

The heating transformers are equipped with painted fiberglass covers to facilitate outdoor operation.

Removable Yoke

When the top yoke of the heating transformer is removable, the cable can be placed or laid into the window instead of fed through the enclosed window.

DC Output

Units may be equipped with rectifiers to facilitate DC testing. Lower output voltages are typically required.

**Carts designed for outdoor,
all weather operation**



High Voltage • High Current • High Power Test Systems and Components

**ISO 9001
CERTIFIED**



www.phenixtech.com

World Headquarters
Phenix Technologies, Inc.
75 Speicher Drive
Accident, MD 21520 USA
Ph: +1.301.746.8118
Fx: +1.301.895.5570
Info@phenixtech.com

Branch Offices

Phenix Systems AG
Riehenstrasse 62A, 4058 Basel, Switzerland
Ph: +41.61.383.2770 • Fx: +41.61.383.2771
Info@phenixsystems.com

Phenix Asia
Zhong Cheng Rd, Sec 1, No 177, 2F, Taipei 11148 Taiwan
Ph: +886.2.2835.9738 • Fx: +886.2.2835.9879
Info@phenixasia.com

